

# ELXTEU

## EDGELIT ALUMINUM EXIT SIGN



### STANDARD



### OPTIONAL

### ILLUMINATION

- Ultra bright, energy efficient, long life Red or Green LEDs.
- UV-stabilized ultra-clear acrylic edgelit panel provides consistent, uniform illumination.
- Double face utilizes factory installed silver or white mylar background panel.

### ELECTRICAL

- Dual 120/277 voltage standard.
- Charge rate power "ON" LED indicator light and push-to-test switch for mandated code compliance testing.
- 4.8V long life, maintenance-free, rechargeable NiCd battery (EM models only).
- Internal solid-state transfer switch automatically connects the internal battery to LED board for minimum 90-minute emergency illumination.
- Fully automatic solid-state, two rate charger initiates battery charging to recharge a discharged battery in 24 hours.

### MOUNTING

- Aluminum mounting canopy included for top, end or back mount.

### HOUSING

- Premium-grade, extruded aluminum housing (also available in optional black or white powder-coated finishes).
- Self-adhesive Chevron appliques and guide template provided for directional indication.

### OPTIONS

- 2C-120V/2C-277V: Voltage-specific dual circuit option on the AC-only unit enables it to be connected to two different supplies at the same time.
- SDT: Self-diagnostic feature performs monthly, biannual, and annual tests to ensure reliable operation and meets electrical and life safety codes.
- USA: Substantial transformation assembly in the U.S. complies with "Assembled in the USA" under the Buy American Act.
- SPV: UL Listed for 208/220/240 Volt, 50/60Hz.
- Custom: Signs available with requested, 'special' wording.

### WARRANTY / LISTING

- Five year warranty on all electronics and housing. Battery prorated for five years.
- Meets UL924, NFPA 101 Life Safety Code, NEC, OSHA, Local and State Codes.
- UL Listed for damp locations (0°C – 50°C).
- Certified to CEC under Title 20 Regulations.

### DIMENSIONS

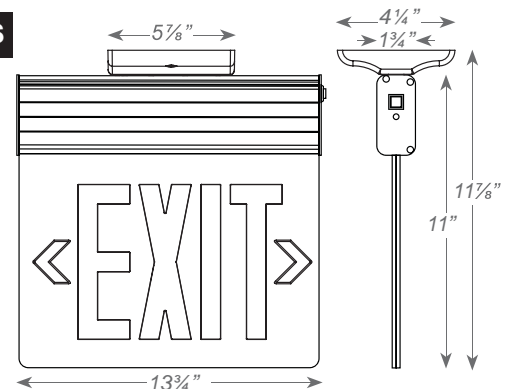

ELXTEU

### ORDERING INFORMATION

Sample Part Number: **ELXTEU1RCAEM**

MODEL	No. of FACES	LETTER COLOR	PANEL	HOUSING COLOR	BATTERY	OPTIONS	
ELXTEU	1	Single Face	R Red	C Clear <sup>1</sup>	W White	(blank) AC-Only	2C-120 2C-277 SDT USA Assembled In USA SPV 208/220/240 Volt, 50/60Hz <sup>4</sup> CUSTOM Custom Wording
	2	Double Face	G Green	M Mirror W White	B Black A Aluminum	EM Battery Backup	

<sup>1</sup> With single face only.

<sup>2</sup> Available only with AC units.

<sup>3</sup> Available only with EM units.

<sup>4</sup> Not available with SDT.